

DIVISION: 07 00 00—THERMAL AND MOISTURE PROTECTION

Section: 07 42 00—Wall Panels

Section: 07 42 63—Fabricated Wall Panel Assemblies

Section: 07 44 23—Ceramic Tile Faced Panels

REPORT HOLDER:

THESIZE SURFACES SL.

EVALUATION SUBJECT:

NEOLITH SKYLINE STRONGFIX FAÇADE SYSTEM

1.0 EVALUATION SCOPE

Compliance with the following codes:

- 2018, 2015, 2012 and 2009 International Building Code® (IBC)
- 2018, 2015, 2012 and 2009 International Residential Code® (IRC)

For evaluation for compliance with codes adopted by Los Angeles Department of Building and Safety (LADBS), see [ESR-3659 LABC and LARC Supplement](#).

Property evaluated:

- Wind resistance
- Types I, II, III and IV construction
- Surface burning characteristics
- Weather Resistance
- Interior finish

2.0 USES

TheSize Surfaces SL. Neolith Skyline Strongfix wall façade system is intended for use as a nonload-bearing exterior wall façade on nonfire-resistant-rated buildings of Type V construction. The system may be used as a nonload-bearing exterior wall covering on nonfire-resistance-rated buildings of Type I, II, III and IV construction when installed in accordance with Section 4.4.

The system is also intended for use in interior applications as part of a Class A interior wall finish.

3.0 DESCRIPTION

3.1 General:

TheSize Surfaces SL. Neolith Skyline Strongfix wall façade system consists of dry-pressed ceramic tiles which are attached at the job site to an aluminum substructure. The

joints between the tiles of the wall façade system are left open. The panels are available in multiple colors.

The Strongfix system is attached to an aluminum railing as described in Section 3.5 by bearing on the railing with kerfs factory cut into the back of the panels (Figures 1 through 6).

3.2 Material:

The dry-pressed, ceramic tiles are 6 mm (0.236 inches) thick, vary between 47¹/₄ inches (1200 mm) and 59¹/₁₆ inches (1500 mm) in width, and 102³/₈ inches (2600 mm) and 141³/₄ inches (3600 mm) in length. Tiles have a unit weight of 2.95 lbs/sf (14.4 kg/m²).

3.3 Aluminum Substructure:

Panel clips in accordance with Section 3.5 shall be attached to an aluminum substructure. The aluminum substructure shall consist of 6063-T5 aluminum alloy channels, proprietary extruded shapes, T-shapes, and angles (Figures 5 through 9).

3.4 Water Resistive Barrier:

The water-resistive barrier must be a minimum of one layer of No. 15 (Type I) asphalt felt, complying with ASTM D226, or be the subject of an ICC-ES evaluation report recognizing the material as a water-resistive barrier.

3.5 Surface-burning Characteristics:

Neolith Skyline Panels, when tested in accordance with ASTM E84, have a flame-spread index of 25 or less and a smoke-developed index of 450 or less.

3.6 Fastening:

The Neolith Skyline Strongfix system utilizes 5/64 inch-thick (2 mm) 6063-T5 aluminum alloy rails which run horizontally. Aluminum fixing clips are inserted into kerf slots along the backside and the top and bottom of the panel and are supported by the horizontal aluminum rail. The horizontal rails are attached to aluminum T-sections running vertically with two M5.5-by-19 mm (3/4-inch) long screws. The vertical T-sections are attached to the building structure with 2.55 mm (3/32-inch) thick 6063-T5 aluminum alloy clip angles. See Figures 5 through 9 for assembly and profiles of substructure components.

4.0 DESIGN AND INSTALLATION

4.1 General:

TheSize Surfaces SL. Neolith Skyline Façade System must be installed over wall assemblies capable of supporting the imposed loads, including, but not limited to, transverse wind

loads. The substructure must be securely fastened to the supporting wall with corrosion-resistant fasteners that are compatible with the wall assembly substrate.

4.2 Design:

The allowable wind loads for TheSize Surfaces SL. Neolith Skyline Façade System are given in Table 1 and for the attachment of the substructure to the underlying wall, must equal or exceed the design uniform transverse wind loads determined in accordance with IBC Chapter 16. The substructure configuration shall be designed such that the allowable deflection of the framing supporting the panel does not exceed $l/240$, where l is the length of the framing between supports.

4.3 Installation:

TheSize Surfaces SL. Neolith Skyline Façade System must be installed in accordance with the manufacturer's published installation instructions, the project specific structural calculations and details and this report. A copy of the manufacturer's published installation instructions must be available on the jobsite at all times during construction.

The system must be installed over wall assemblies complying with 2018 IBC Section 1402.3 (2015, 2012 and 2009 IBC Section 1403.3), using the substructure systems and attachments described in Section 3.3 and 3.5 of this report.

4.4 Types I, II, III or IV (Noncombustible) Construction:

Neolith Skyline Panels have been tested in accordance with ASTM E136 and comply with the 2018, 2015, and 2012 IBC Section 703.5 (2009 IBC Section 703.4). The panels are classified as noncombustible building construction materials and may be installed on buildings of Types I, II, III, IV and V construction. When the wall panels are used on exterior wall assemblies which include a combustible water-resistive barrier, the building height is limited to 40 feet (12.2 m) above grade.

The following exterior wall assembly, consisting of Neolith Skyline Panels, has been tested in accordance with NFPA 285 and may be installed on buildings of Types I, II, III and IV construction of any height:

- Wall framing: 6-inch-deep (152 mm) No. 18 gauge [0.0428 inch (1.09 mm)] steel studs spaced at 24 inches (610 mm) attached at the top and bottom with one #6 x 1/2-inch-long self-drilling screw per flange.
- Interior cladding: 5/8-inch-thick (15.9 mm) National Gypsum Gold Bond® Fire-Shield® gypsum board. The gypsum board is attached to the steel stud framing with #6 x 1 1/4-inch long bugle head self-drilling screws with a nominal spacing of 8 inches (203 mm) around the perimeter of the sheathing board and 12 inches (305 mm) on center in the field of the board. All joints are taped with USG Sheetrock® Brand paper joint tape. All joints and fastener heads are spackled with USG Sheetrock® Brand joint compound.
- Safing: Johns Manville MinWool® Safing pieces with a nominal density of 4.0 lbs/ft³ (64.1 kg/m³) are installed per the manufacturer's installation instructions to fit into each stud cavity.
- Exterior wall sheathing: 1/2-inch (12.7 mm) thick Georgia-Pacific DensGlass® exterior gypsum sheathing. Exterior sheathing is attached to steel stud framing with #6 x 1 1/4-inch long bugle head self-drilling screws with a nominal spacing of 8 inches (203 mm) around the perimeter of the sheathing board and 12 inches (305 mm) on center in the field of the board. Horizontal and vertical joints of the wall sheathing shall be treated with a 1/4-inch-thick (6.4 mm) by 1-inch

(25.4 mm) wide application of Henry® Blueskin® 925 BES sealant.

- Water-resistive barrier: A coat of 574 Blueskin LVC adhesive is applied over the wall sheathing at a uniform rate of 1 gallon per 250 square feet (16.3 L per 100 square meters). After the adhesive is dry, Henry Blueskin SA water-resistive barrier is applied over the wall sheathing. Laps of the Henry Blueskin SA barrier are 2 inches wide (50.8 mm).
- Exterior insulation: 1 1/2-inch (38.1 mm) thick Roxul™ ComfortBatt® Insulation over the exterior side of the water-resistive barrier. Insulation is retained in place with 3-inch-long (76.2 mm) base insulation hangers attached to each wall stud at a nominal 4 feet (1.22 m) on center vertically.
- Window openings: Window openings are formed with No. 18 gauge [0.0428 inch (1.09 mm)] steel track mechanically fastened with #6 1/2-inch long self-drilling, pan head fasteners at each corner. Once the exterior cladding is installed, windows are flashed with flat sheets of 18 gauge galvanized steel spanning from the interior gypsum cladding to the exterior cladding panels. Flashing is affixed to the window opening perimeter framing with #12 1-inch-long hex head, self-drilling fasteners spaced 10-inches on center.
- Exterior cladding: Neolith Strongfix cladding substructure is attached to the wall studs with ESC aluminum brackets. The ESC brackets are attached to the wall studs with three 1/4-inch (6.4 mm) by 2-inch-long (50.8 mm) hex head self-drilling screws. Vertical profile "T" sections are attached to the ESC brackets with two #12 x 1 1/2-inch-long hex head self-drilling fasteners through the slots and two #12 x 1 1/2-inch long hex head self-drilling fasteners through the bracket and vertical profile "T" section. The horizontal profiles are attached to the vertical "T" profile with two #12 x 3/4-inch long hex head self-drilling fasteners at each intersection. The Neolith Panels are friction-set by "hooking" the factory installed Strongfix "fixing profile" extrusions on the backs of the panels to the field-installed horizontal profiles (See Figures 1 through 6 for general installation details). The horizontal and vertical panel reveals are set to 9/32-inches (7 mm).

5.0 CONDITIONS OF USE

The Neolith Skyline Façade System described in this report complies with, or is a suitable alternative to what is specified in, those codes listed in Section 1.0 of this report, subject to the following conditions:

- 5.1 Installation must comply with this report, the manufacturer's published installation instructions, and applicable code. If there is a conflict between the manufacturer's published installation instructions and this report, this report governs.
- 5.2 The fasteners, underlying substructure, and wall must be adequate to resist the positive and negative transverse wind loads shown in Table 1.
- 5.3 Drawings, design details and calculations verifying compliance with this report and adequacy of the connections to the substrate must be submitted to the code official for approval. The drawings and calculations must be prepared by a registered design professional where required by the statutes of the jurisdiction in which the project is to be constructed.
- 5.4 The Neolith Skyline Façade System must be installed by qualified installers recognized by TheSize Surfaces SL.

- 5.5 A water resistive barrier complying with IBC Section 1403.2 must be installed behind the wall panel system.
- 5.6 The use of Neolith Skyline Façade Panels on exterior wall types of Types I, II, III and IV construction which contain combustible materials or are greater than 40 feet in height (12.2 m) is outside the scope of this report except when installed in accordance with Section 4.4.
- 5.7 The panels are manufactured in Almazora, Spain under a quality control program with inspections by ICC-ES.

6.0 EVIDENCE SUBMITTED

- 6.1 Data in accordance with the ICC-ES Acceptance Criteria for Façade and Wall Cladding Systems with Porcelain, Ceramic or Terra Cotta Panels (AC504), dated October 2018.

7.0 IDENTIFICATION

- 7.1 Each panel is marked with the report holder’s name (Neolith Skyline) and address, the product name, thickness, color and finish, production date code, and the evaluation report number (ESR-3659).
- 7.2 The report holder’s contact information is the following:

**THESIZE SURFACES SL.
P.I. CAMI FONDO
SUPOI 8, 31 DELS IBERS ST.
ALMAZORA/CASTELLON/12550
SPAIN
+34 964 652 233
www.neolith.com**

TABLE 1—MAXIMUM PROFILE SPACING AND ALLOWABLE TRANSVERSE LOADS

PANEL THICKNESS (Inches)	SYSTEM	MAXIMUM HORIZONTAL PROFILE SPACING (inches)	MAXIMUM VERTICAL “T” PROFILE SPACING (inches)	ALLOWABLE TRANSVERSE WIND LOAD ¹ (psf)	
				Positive	Negative
1/4	Strongfix	28 ¹ / ₈ ”	30 ³ / ₈ ”	35.8	-25.4

For SI: 1 inch = 25.4 mm; 1 psf = 4.88 kg/m²

¹Maximum transverse wind load capacity determined using ASTM E330 testing procedure. Design of the attachment to the building structure must be in accordance with Section 4.2 of this report.

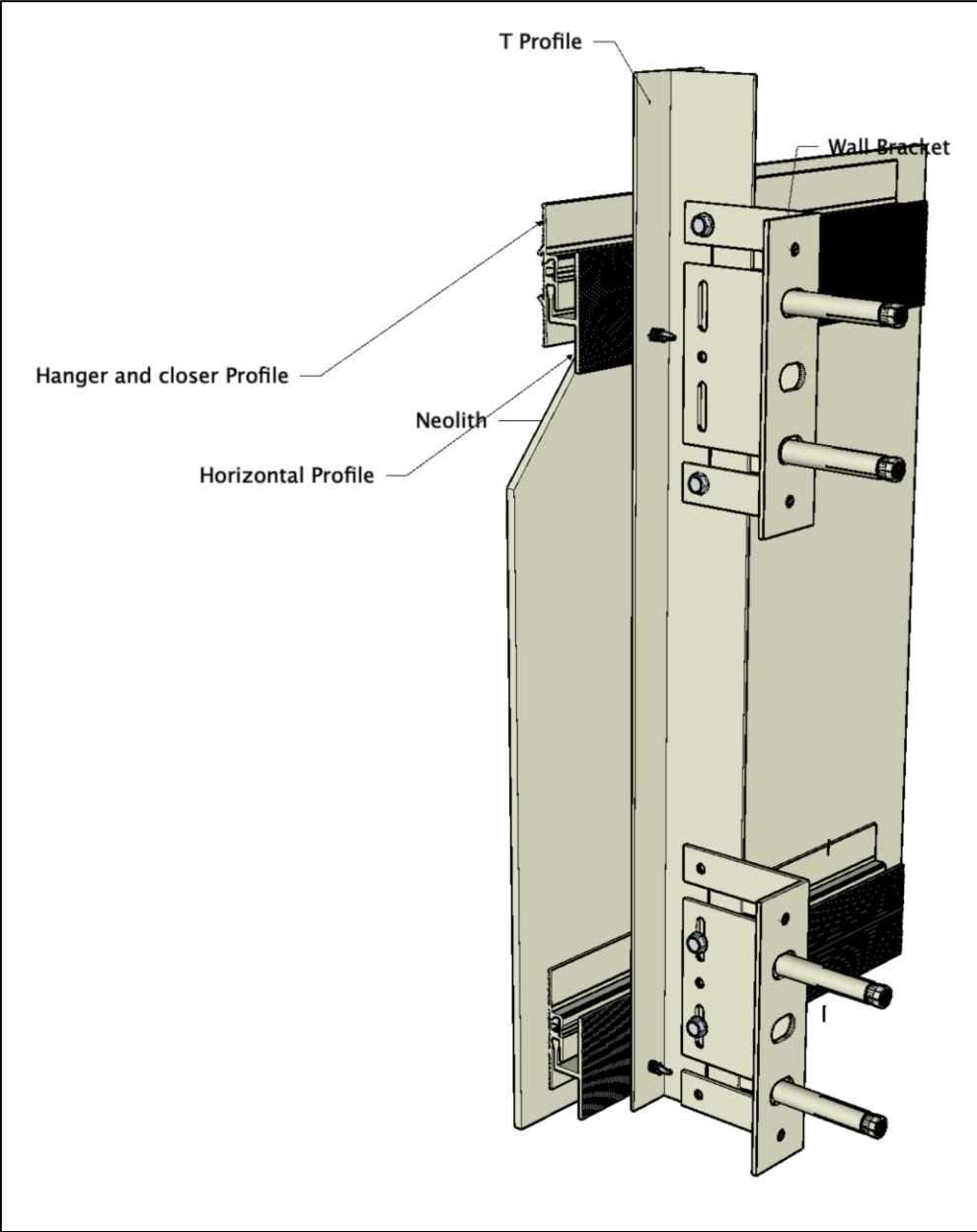

FIGURE 1—ASSEMBLY OF STRONGFIX SYSTEM COMPONENTS

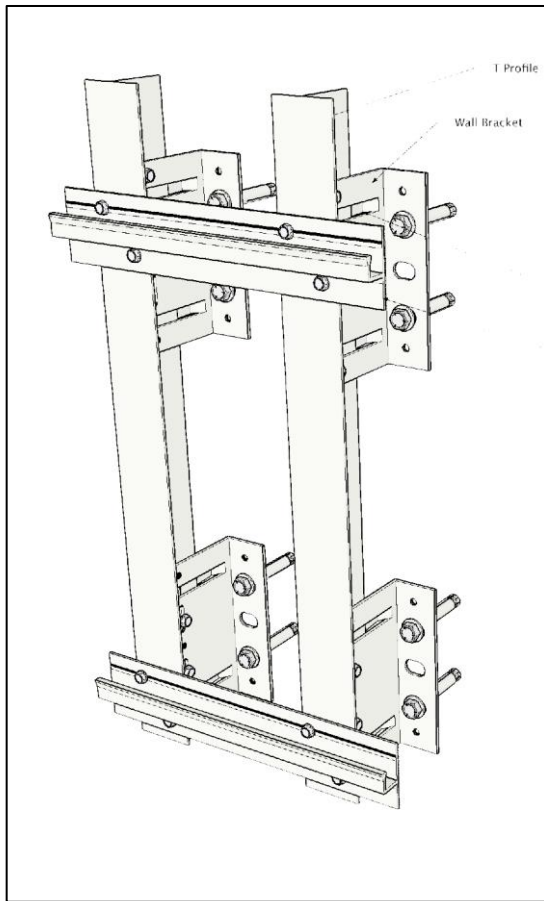

FIGURE 2—SUBSTRUCTURE ASSEMBLY

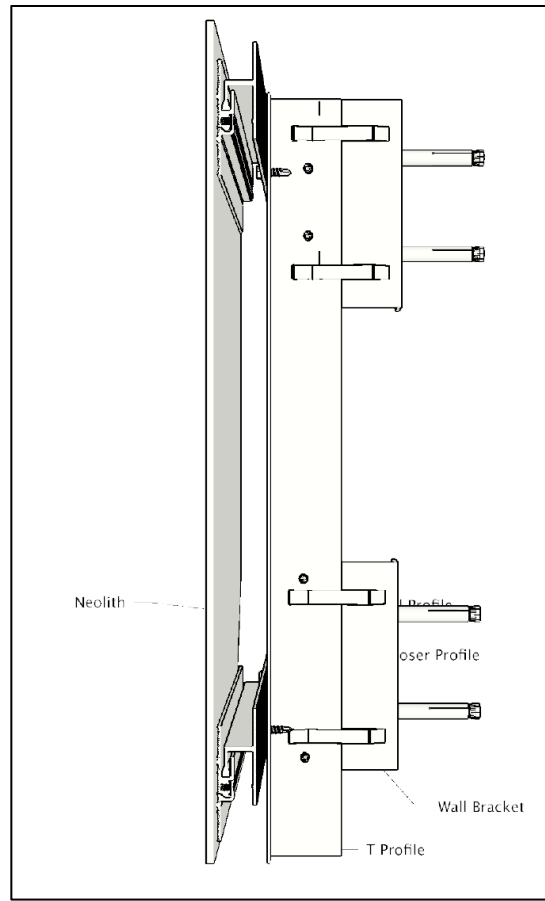

FIGURE 3—SIDE VIEW OF SYSTEM ASSEMBLY

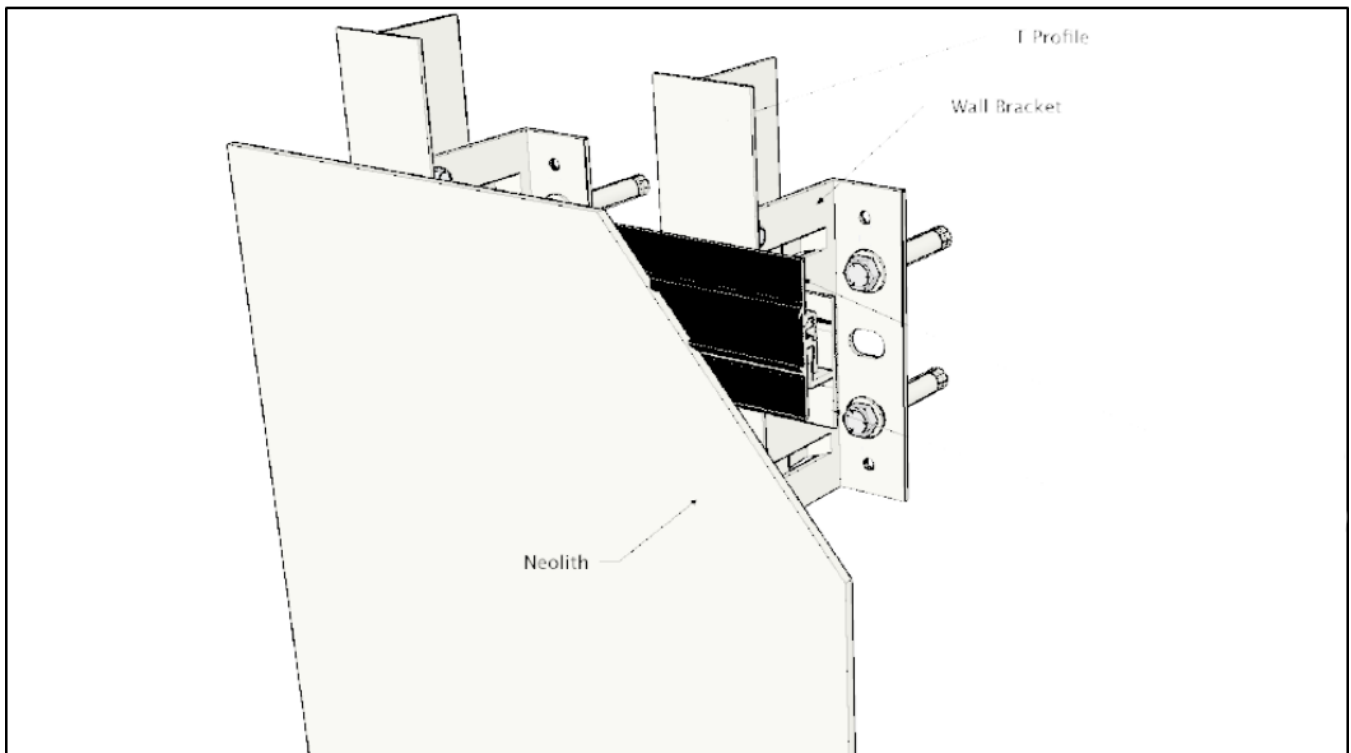

FIGURE 4—FRONT VIEW OF SYSTEM ASSEMBLY

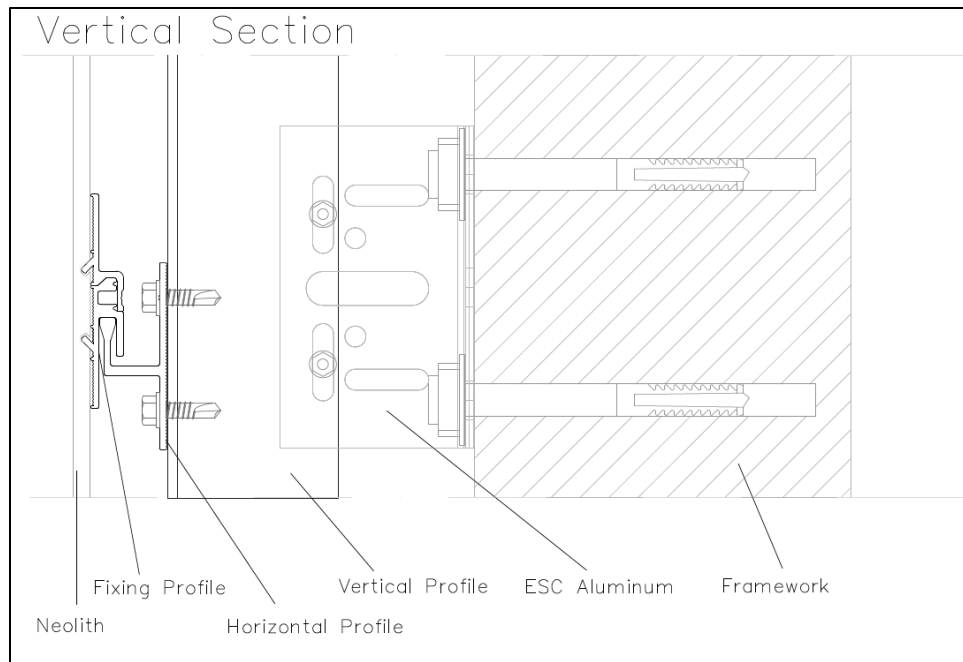

FIGURE 5—VERTICAL CROSS SECTION OF ASSEMBLY OF STRONGFIX SYSTEM COMPONENTS

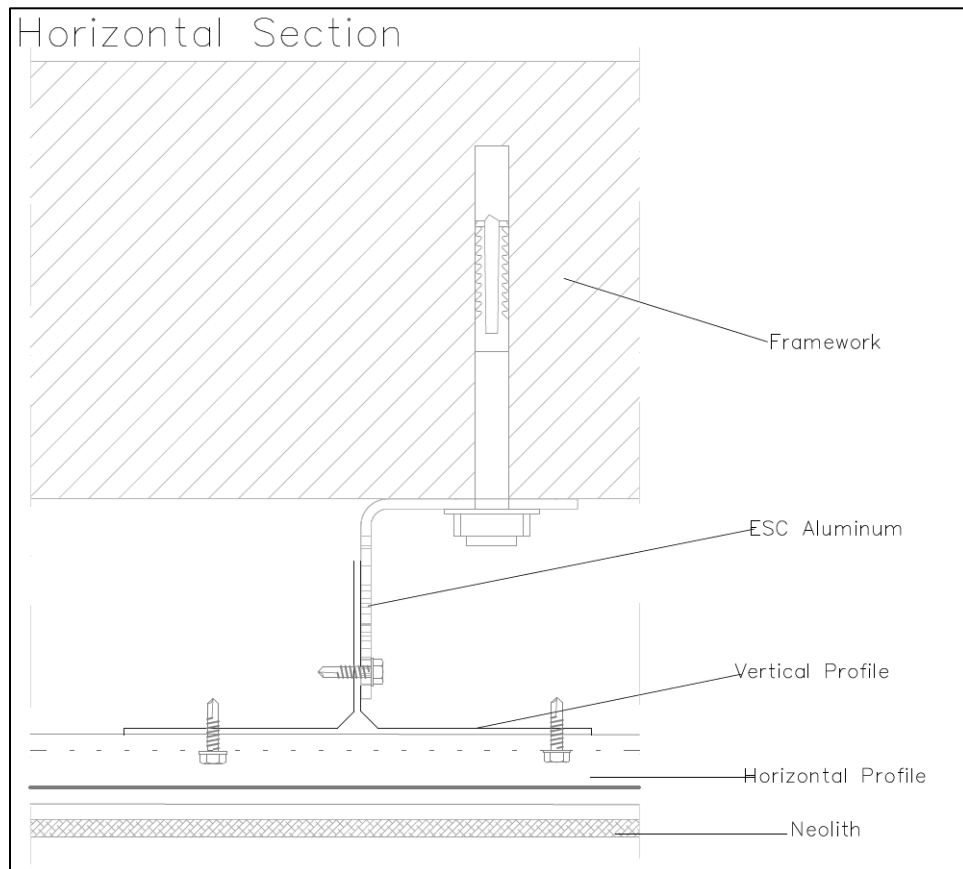

FIGURE 6—HORIZONTAL CROSS SECTION OF ASSEMBLY OF STRONGFIX SYSTEM COMPONENTS

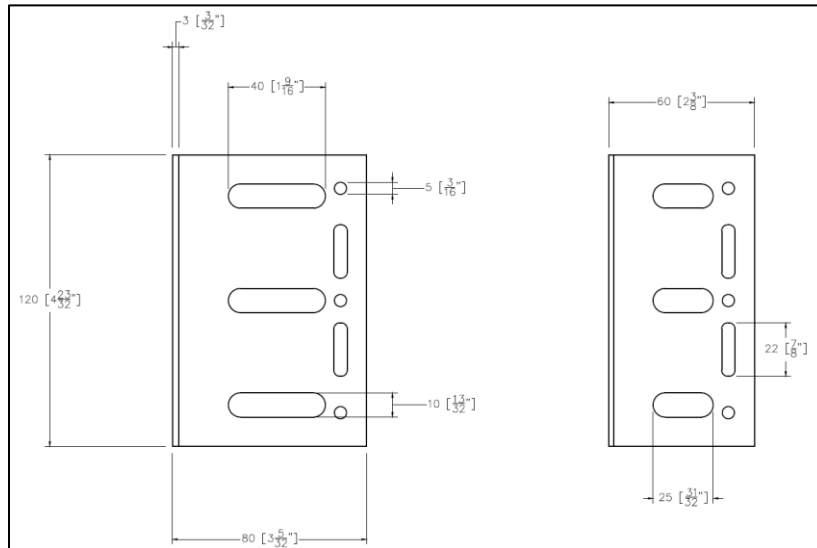

FIGURE 7—ESC ALUMINUM BRACKET mm [inches]

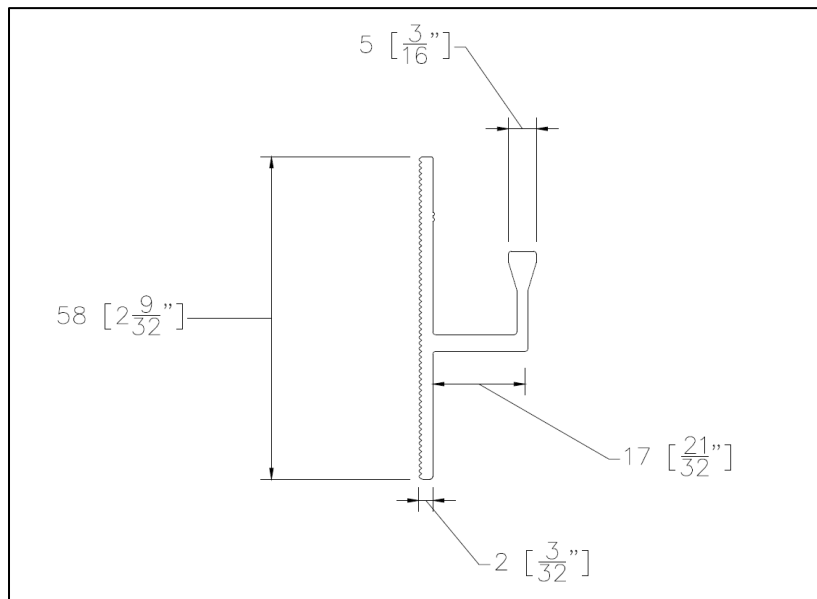

FIGURE 8—HORIZONTAL ALUMINUM PROFILE mm [inches]

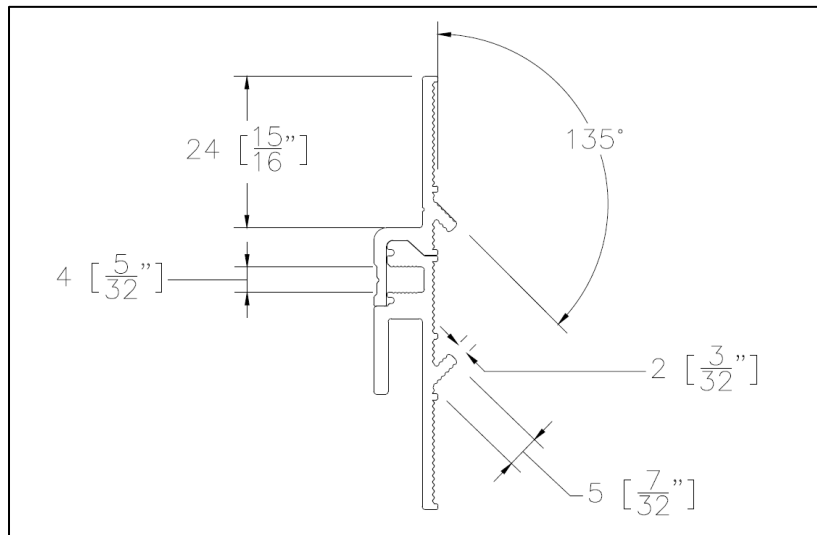

FIGURE 9—FIXING ALUMINUM PROFILE mm [inches]

DIVISION: 07 00 00—THERMAL AND MOISTURE PROTECTION

Section: 07 42 00—Wall Panels

Section: 07 42 63—Fabricated Wall Panel Assemblies

Section: 07 44 23—Ceramic Tile Faced Panels

REPORT HOLDER:

THESIZE SURFACES SL.

EVALUATION SUBJECT:

NEOLITH SKYLINE STRONGFIX FAÇADE SYSTEM

1.0 REPORT PURPOSE AND SCOPE

Purpose:

The purpose of this evaluation report supplement is to indicate that TheSize Surfaces SL. Neolith Skyline Strongfix wall façade system, described in ICC-ES evaluation report [ESR-3659](#), has also been evaluated for compliance with the codes noted below as adopted by the Los Angeles Department of Building and Safety (LADBS).

Applicable code editions:

- 2020 *City of Los Angeles Building Code* (LABC)
- 2020 *City of Los Angeles Residential Code* (LARC)

2.0 CONCLUSIONS

The TheSize Surfaces SL. Neolith Skyline Strongfix wall façade system, described in Sections 2.0 through 7.0 of the evaluation report [ESR-3659](#), complies with LABC Section 703.5 and Chapter 14, and LARC Chapter 7, and is subjected to the conditions of use described in this supplement.

3.0 CONDITIONS OF USE

The TheSize Surfaces SL. Neolith Skyline Strongfix wall façade system, described in this evaluation report supplement must comply with all of the following conditions:

- All applicable sections in the evaluation report [ESR-3659](#).
- The design, installation, conditions of use and labeling are in accordance with the 2018 *International Building Code*® (IBC) and 2018 *International Residential Code*® (IRC) provisions noted in the evaluation report [ESR-3659](#).
- The design and installation are in accordance with additional requirements of LABC Chapters 14 and 16.
- The TheSize Surfaces SL. Neolith Skyline Strongfix wall façade system has not been evaluated under LABC Chapter 7A or LARC Section R337 for use in the exterior design and construction of new buildings located in any Fire Hazard Severity Zone within State Responsibility Areas or any Wildland-Urban Interface Area.

This supplement expires concurrently with the evaluation report, issued July 2019 and revised March 2020.

DIVISION: 07 00 00—THERMAL AND MOISTURE PROTECTION

Section: 07 42 00—Wall Panels

Section: 07 42 63—Fabricated Wall Panel Assemblies

Section: 07 44 23—Ceramic Tile Faced Panels

REPORT HOLDER:

THESIZE SURFACES SL.

EVALUATION SUBJECT:

NEOLITH SKYLINE STRONGFIX FAÇADE SYTEM

1.0 REPORT PURPOSE AND SCOPE

Purpose:

The purpose of this evaluation report supplement is to indicate that TheSize Surfaces SL. Neolith Skyline Strongfix wall façade system, recognized in ICC-ES evaluation report ESR-3659, has also been evaluated for compliance with the codes noted below.

Applicable code edition(s):

- 2019 *California Building Code* (CBC)

For evaluation of applicable chapters adopted by the California Office of Statewide Health Planning and Development (OSHPD) and Division of State Architects (DSA), see Sections 2.1.1 and 2.1.2 below.

- 2019 *California Residential Code* (CRC)

2.0 CONCLUSIONS

2.1 CBC:

TheSize Surfaces SL. Neolith Skyline Strongfix wall façade system, described in Sections 2.0 through 7.0 of the evaluation report ESR-3659, complies with CBC Section 703.5 and Chapter 14, provided the design and installation are in accordance with the 2018 *International Building Code*® (IBC) provisions noted in the evaluation report and the additional requirements of CBC Chapter 14 and 16, as applicable.

The system has not been evaluated under CBC Chapter 7A for use in the exterior design and construction of new buildings located in any Fire Hazard Severity Zone within State Responsibility Areas or any Wildland-Urban Interface Area.

2.1.1 OSHPD:

The applicable OSHPD Sections of the CBC are beyond the scope of this supplement.

2.1.2 DSA:

The applicable DSA Sections of the CBC are beyond the scope of this supplement.

2.2 CRC:

TheSize Surfaces SL. Neolith Skyline Strongfix wall façade system, described in Sections 2.0 through 7.0 of the evaluation report ESR-3659, complies with CRC Chapter 7, provided the design and installation are in accordance with the 2018 *International Residential Code*® (IRC) provisions noted in the evaluation report.

The system has not been evaluated under CRC Section R337 for use in the exterior design and construction of new buildings located in any Fire Hazard Severity Zone within State Responsibility Areas or any Wildland-Urban Interface Area.

The products recognized in this supplement have not been evaluated for compliance with the *International Wildland–Urban Interface Code*®.

This supplement expires concurrently with the evaluation report, issued July 2019 and revised March 2020.

DIVISION: 07 00 00—THERMAL AND MOISTURE PROTECTION**Section: 07 42 00—Wall Panels****Section: 07 42 63—Fabricated Wall Panel Assemblies****Section: 07 44 23—Ceramic Tile Faced Panels**

THE SIZE SURFACES SL.

EVALUATION SUBJECT:

NEOLITH SKYLINE STRONGFIX FAÇADE SYSTEM

1.0 REPORT PURPOSE AND SCOPE**Purpose:**

The purpose of this evaluation report supplement is to indicate that TheSize Surfaces SL. Neolith Skyline Strongfix wall façade system, recognized in ICC-ES master evaluation report ESR-3659, has also been evaluated for compliance with the codes noted below.

Applicable code editions:

- 2017 Florida Building Code—Building
- 2017 Florida Building Code—Residential

2.0 CONCLUSIONS

TheSize Surfaces SL. Neolith Skyline Strongfix wall façade system, described in Sections 2.0 through 7.0 of the master evaluation report ESR-3659, complies with the *Florida Building Code—Building* and the *Florida Building Code—Residential*, provided the design and installation are in accordance with the *International Building Code*® provisions noted in the master report.

Use of TheSize Surfaces SL. Neolith Skyline Strongfix wall façade system for compliance with the High-Velocity Hurricane Zone provisions of the *Florida Building Code—Building* and the *Florida Building Code—Residential* has not been evaluated, and is outside the scope of this supplemental report.

For products falling under Florida Rule 9N-3, verification that the report holder's quality assurance program is audited by a quality assurance entity approved by the Florida Building Commission for the type of inspections being conducted is the responsibility of an approved validation entity (or the code official when the report holder does not possess an approval by the Commission).

This supplement expires concurrently with the master report, issued July 2019 and revised March 2020.